

Chromatographic Methods of Analysis

Section 2: Planar Chromatography

Prof. Tarek A. Fayed

- Planar chromatography includes two types:

1- Thin Layer Chromatography (TLC).

2- Paper Chromatography (PC).

Thin Layer Chromatography (TLC)

The stationary phase is a thin and uniform layer of:

- A solid adsorbent, usually silica gel (SiO_2), alumina (Al_2O_3), or cellulose,
 - A substance which fluoresces under UV light often incorporated into the stationary phase (Zinc sulfide).
 - Binders: These are materials used to hold the thin layer of the coating material into the surface of the supporting plates (CaSO_4 , SiO_2 or starch).
- coated into supporting plates of glass, metal or plastic sheets.

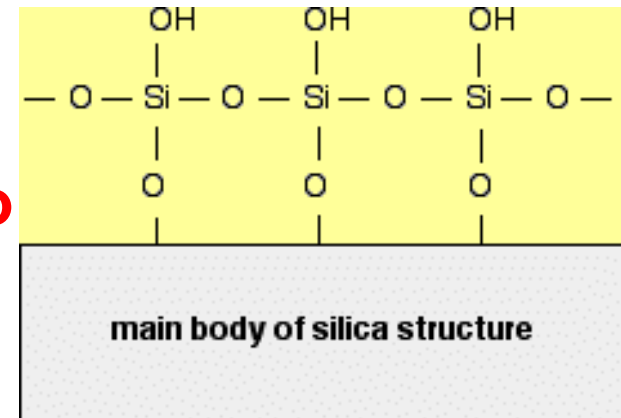

Stationary Phase: Silica (SiO_2) and Alumina (Al_2O_3)

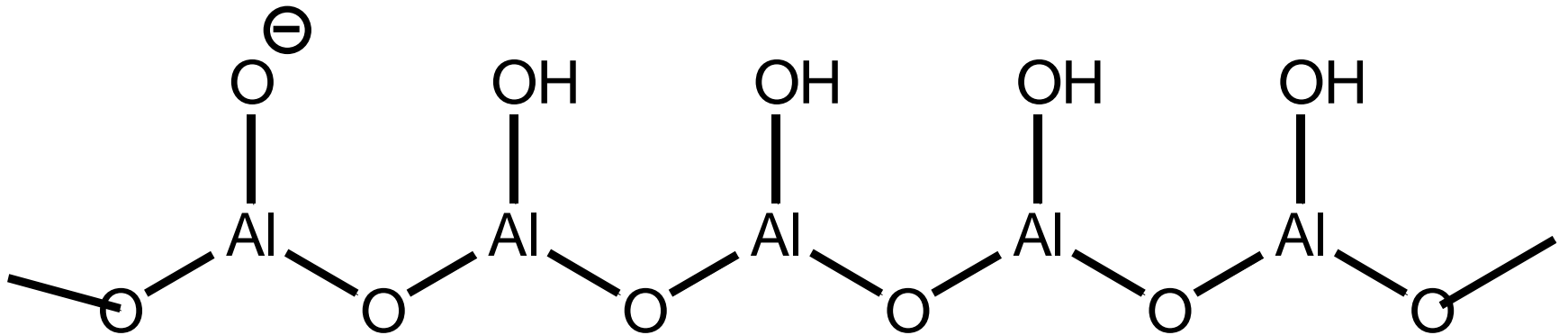
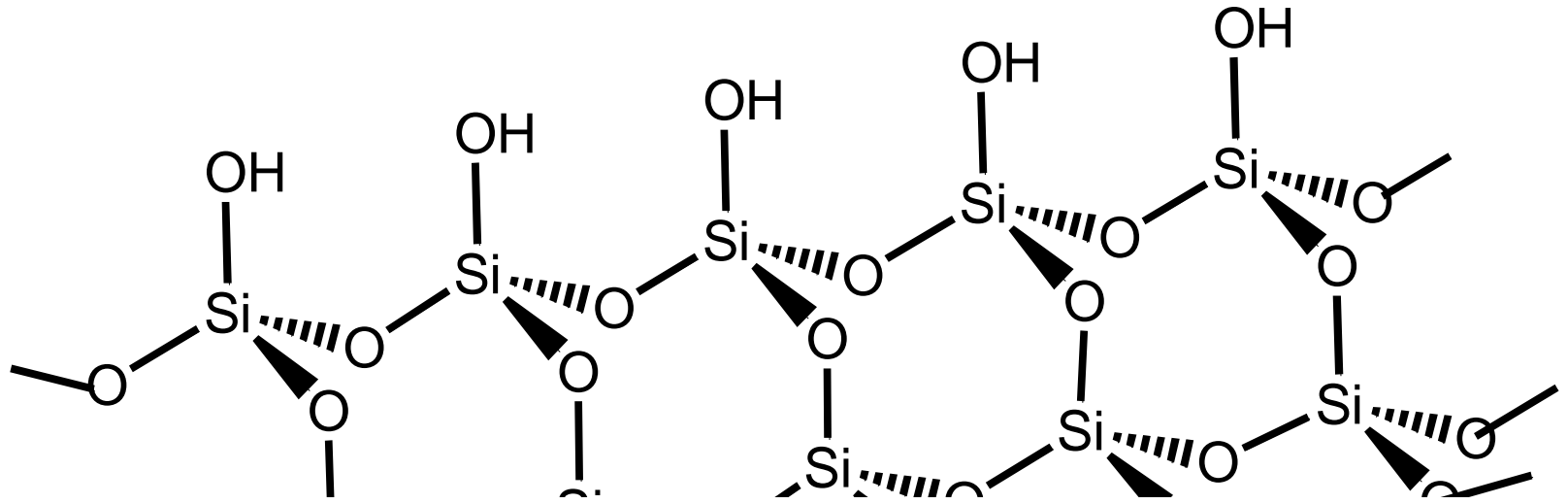

- Mobile phase is a suitable liquid solvent or mixture of solvents.

TLC Experimental Setup

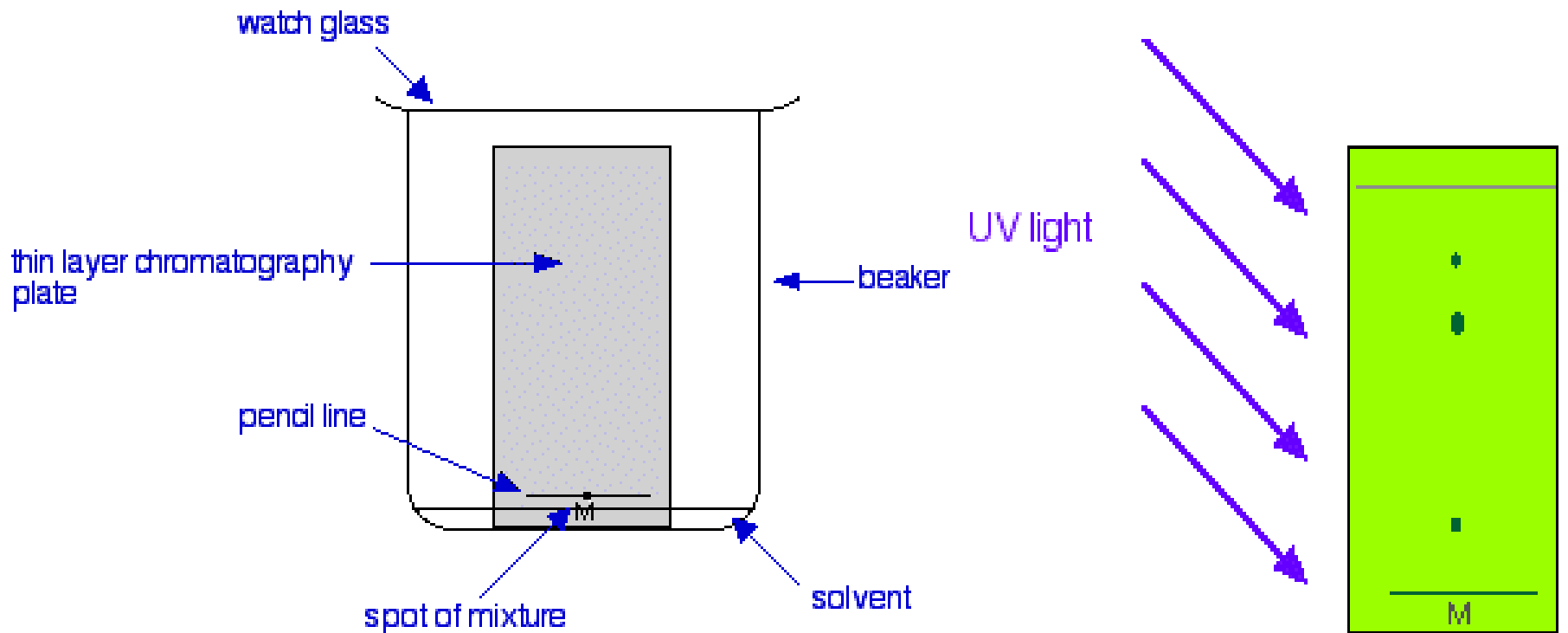

TL before elution

TL after separation

Procedures of separation by TLC

1- Preparing the plate and separation chamber

- A) Choose a container that is large enough and can be closed.
- B) Add a few cm³ of the mobile phase solvent to the chamber.



Seal the chamber and allow it to stand for while. The atmosphere of the chamber should be saturated with the solvent vapors before running samples. This is to prevent the evaporation of solvent as it rises up the stationary phase. Also, it allows for better development of the chromatograms.

2: Preparing the stationary phase

A) Prepare the TLC plate:

- Mix: Adsorbent, Small amount of an inert binder, Water.
- Spread a thin layer (no more than a few mm) of the mixture on a non-reactive support.
- After the plate is dried, it is activated by heating in an oven for approximately 30 minutes at 110°C.
- Draw a line of origin approximately 1 to 1.5 cm (**start line**) from the bottom filter paper.
- Indicate where each sample will be added.

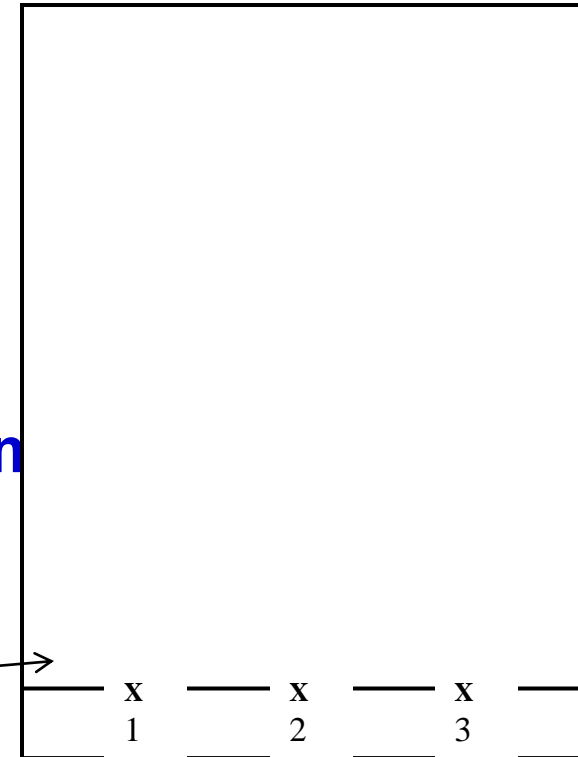

3- Sample Application (Spotting):

- Samples are applied as a solution in any volatile solvent using glass capillaries for qualitative, preparative applications. Graduated syringes are used for qualitative analysis.
- The spots must be about 1 to 1.5 cm away from the bottom of the plate and 0.5 cm away from the plate sides and 0.5 cm away from each other.

A concentration of about 1% (1g in 100ml) is good.

The image shows a sample run at three different concentrations. The left plate was too concentrated, the spots are running together. The other two plates yielded good separation.

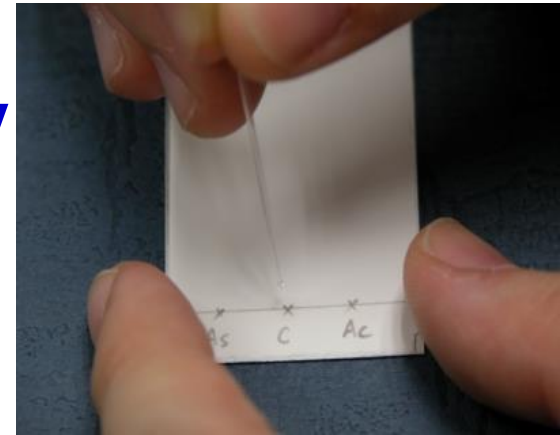

4- Developing the chromatograms

- When the sample spot has dried, the TLC plate is placed into the chamber containing the solvent (Jar).
- It is important that the sample spot is above the level of the solvent.
- Allow the solvent to rise until it almost reaches the top of the plate (**End line**), remove the plate from the chamber.
- If the sample spots are visible, mark their positions.

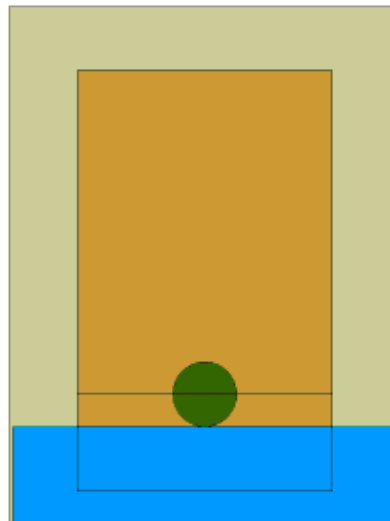

Shape of the developing Jar

Development techniques:

A- Ascending technique:

1- Single development:

The solvent system is allowed to move slow for one time through the stationary phase against gravity.

2- Repeated developments:

a- Multiple developments:

The plates are developed more than one time using the same solvent system.

Thin layer

b- Stepwise developments:

The plates are developed more than one time using different solvent systems.

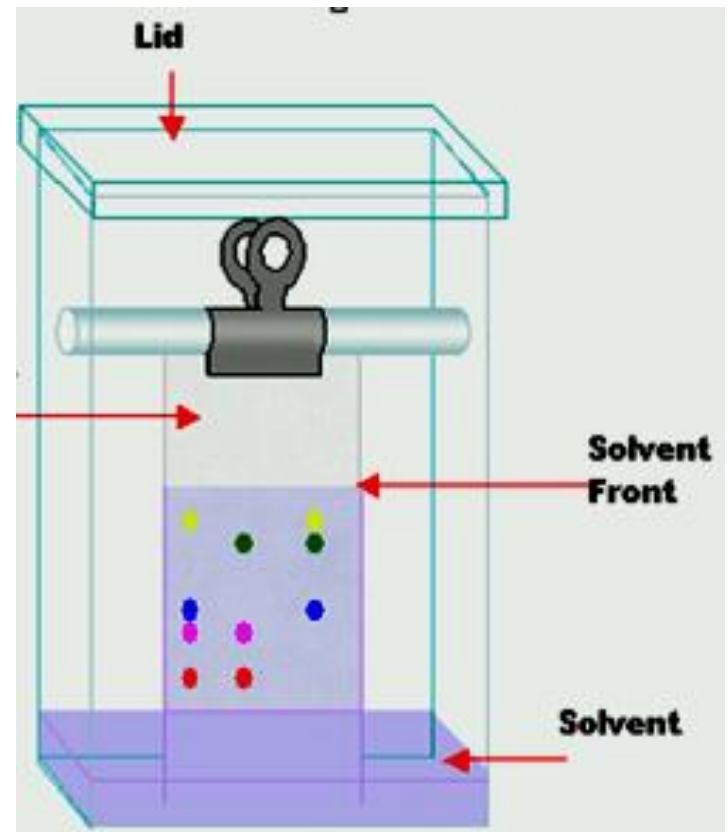

Development of a two-components mixture

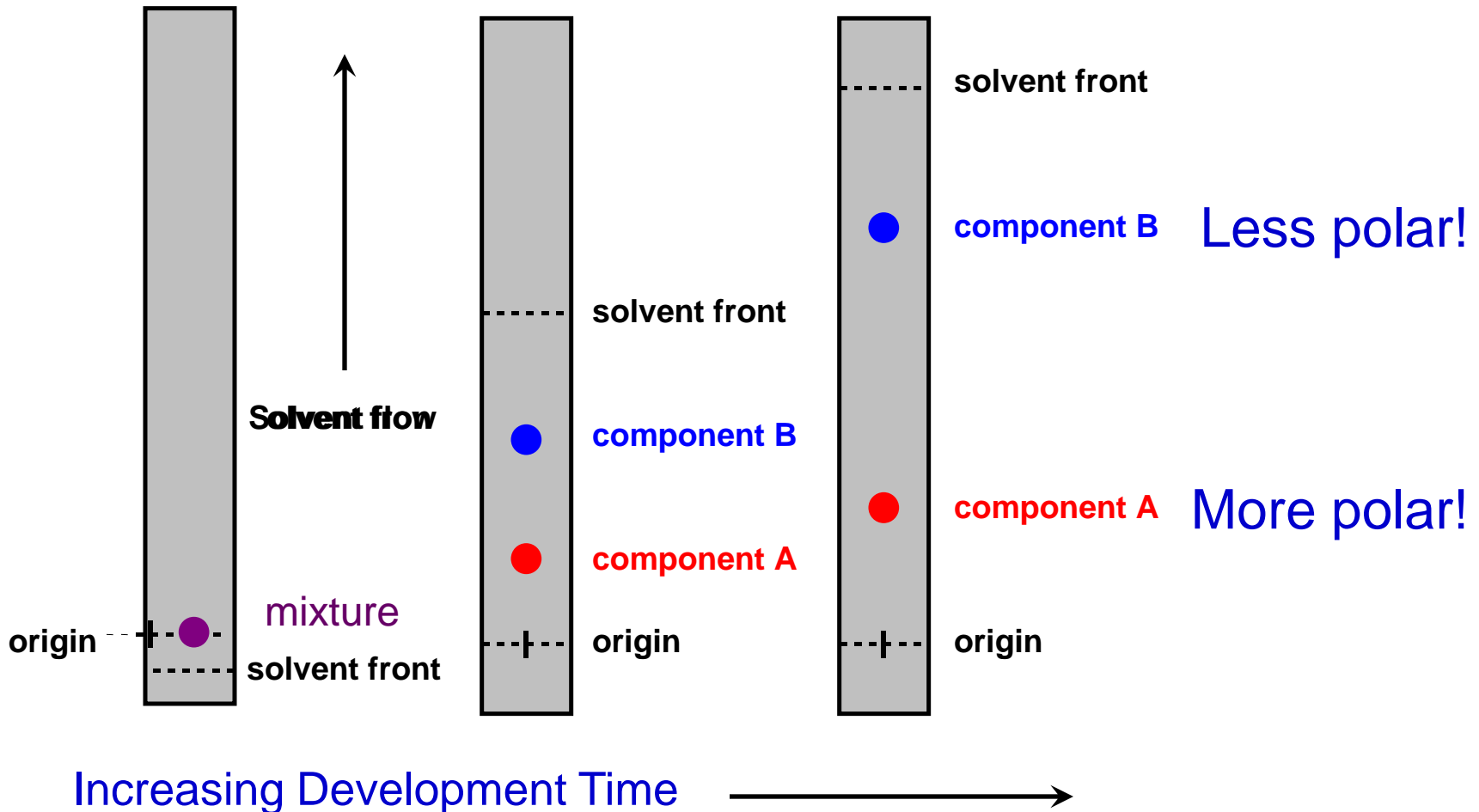

B- Descending technique

- In this method, the solvent is kept in a trough at the top of the chamber and is allowed to flow down the paper or thin layer, by capillary action as well as by the gravitational force.
- In this case, the flow is more rapid as compared to the ascending method.

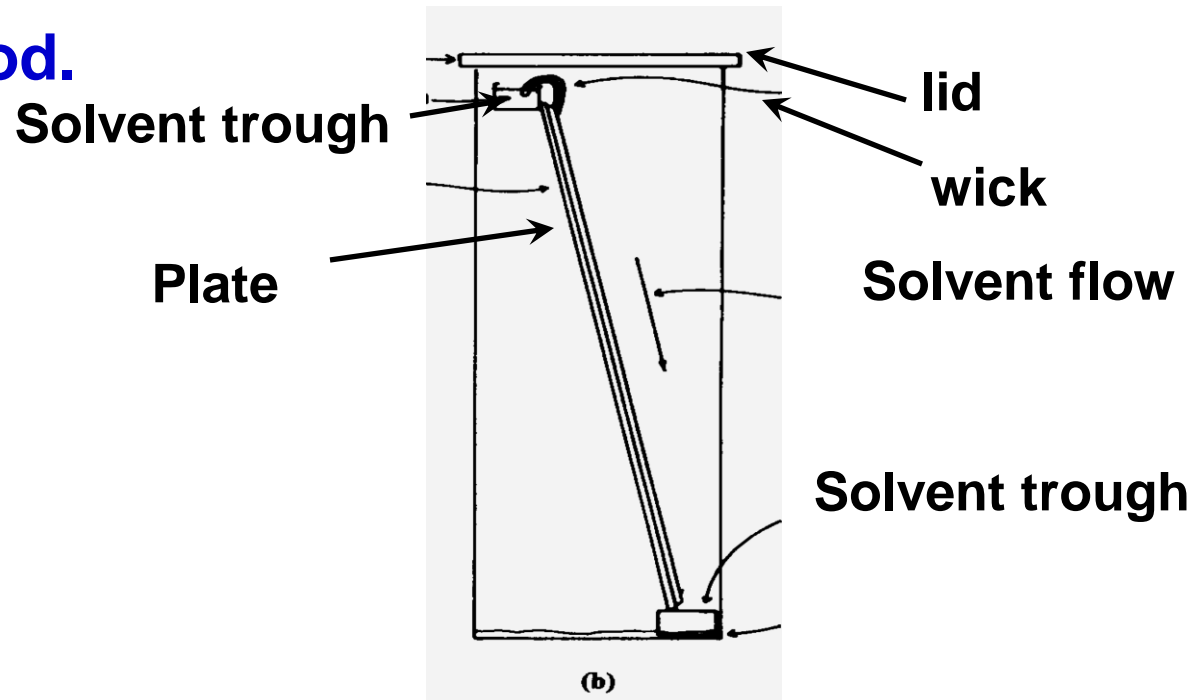

C- Two-dimensional development:

- It is used to separate mixture containing large number of components or mixture of two closely related compounds (which can't be separated well by one dimensional) into pure compound.
- The spots are applied to one corner and the plate developed as usual. The plate is then rotated 90° and then developed again.
- This method allow better separation of related compounds.

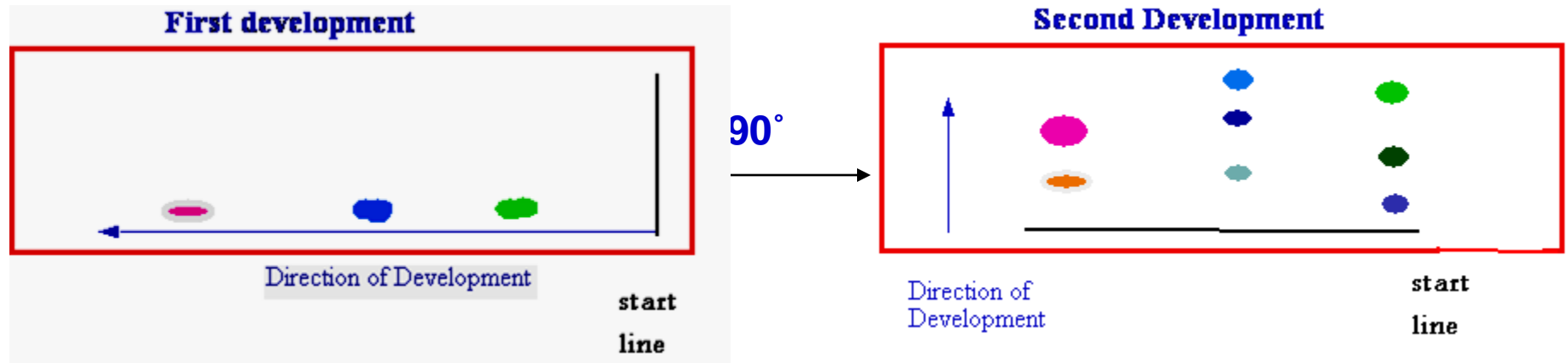

D- Centrifugal (chromatotron):

- This method requires the use of Chromatotron. Simply it is composed of motor rotate in high speed (about 1000 rpm) to accelerate the speed of the mobile phase.
- Circular plates are used and the mixture is applied to the center of the plate.
- The mobile phase is also allowed to flow from the center of the plate to the edges.
- The separated materials will appear as concentric zones. Chromatotron is used only for preparative work.

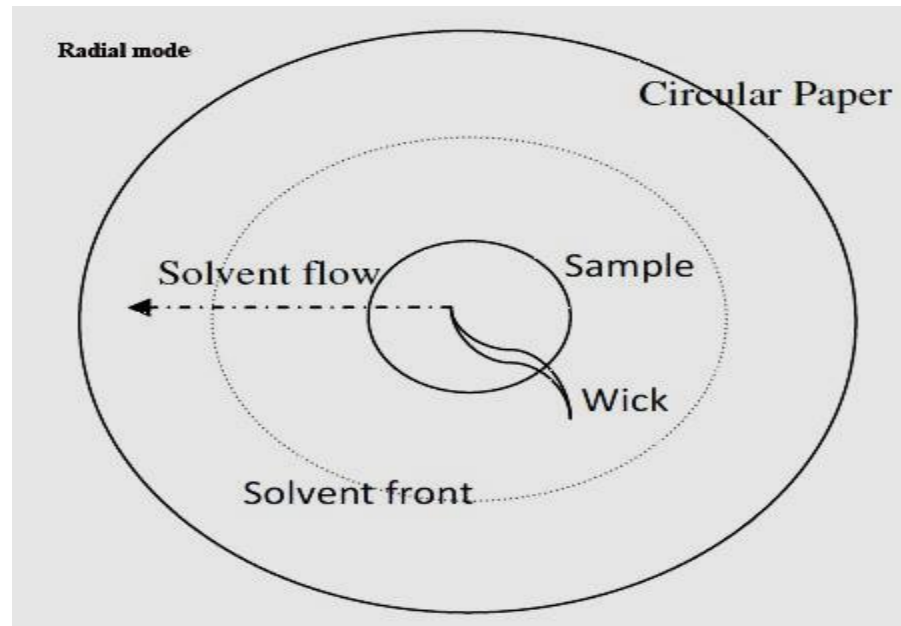

5- Detection of spots (Visualization of spots):

A- The coloured components: are visualized (detected and identified) from its colors and marked by a pencil.

B- Colourless components: two ways are used to detect colourless components

1- Chemical methods: (Destructive methods)

The plates are sprayed with coloring reagents and then heated in oven where organic compounds will give certain coloures.

- **Universal reagents:** Anisaldehyde / H_2SO_4 or Vanillin / H_2SO_4 and Iodine vapor.

- **Specific colored reagents:**

As Ninhydrin (for amino acids),

Rhodamine B (for lipids)

Aniline phthalate (for carbohydrates).

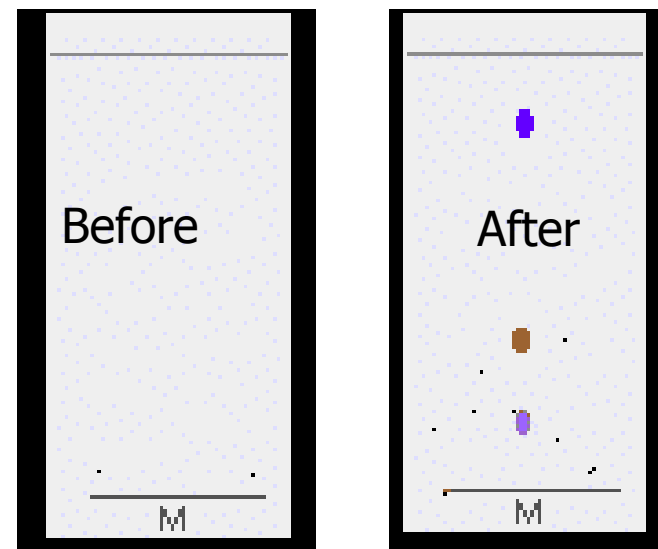

2- Physical methods (Non – Destructive methods):

In these methods the materials can be recovered. It includes;

A) UV light irradiation for fluorescent compounds:

- Substance which can fluoresce under UV light is added to stationary phase.

So, when the TLC plate is exposed to UV light at 254 nm, the entire plate will glow.

- On the final chromatogram, the glow will be masked at positions where spots are located.

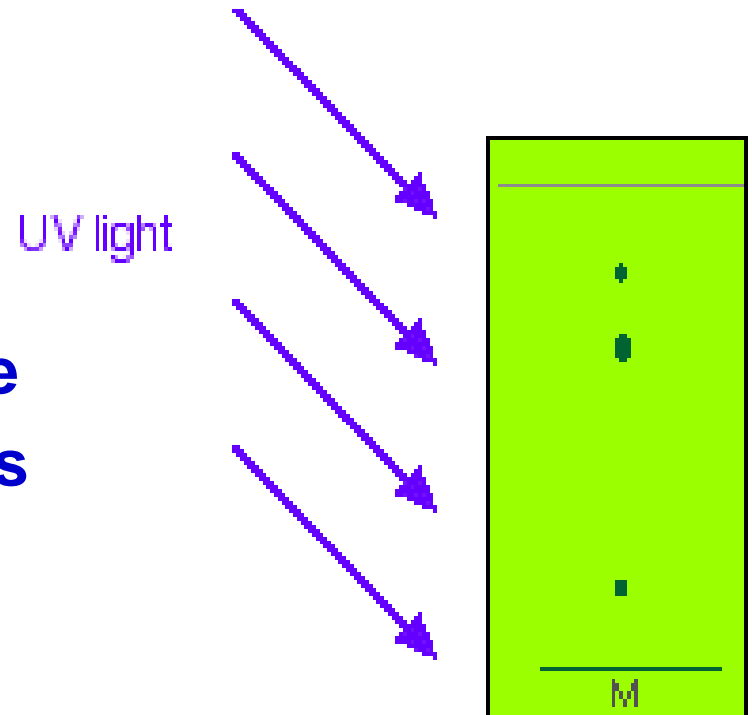

B) Scanning Densitometry

- Scanning of TLC plates employing optical instrumentation has been extensively used for both detection (accurate identification of the spot position) and the precise quantitative estimation of the components.
- The incident light may be adsorbed, diffusely scattered, or transmitted through the plate.

Therefore, the plate surface can be examined employing measurement of either reflected light, transmitted light or fluorescent light.

Single Beam Densitometers

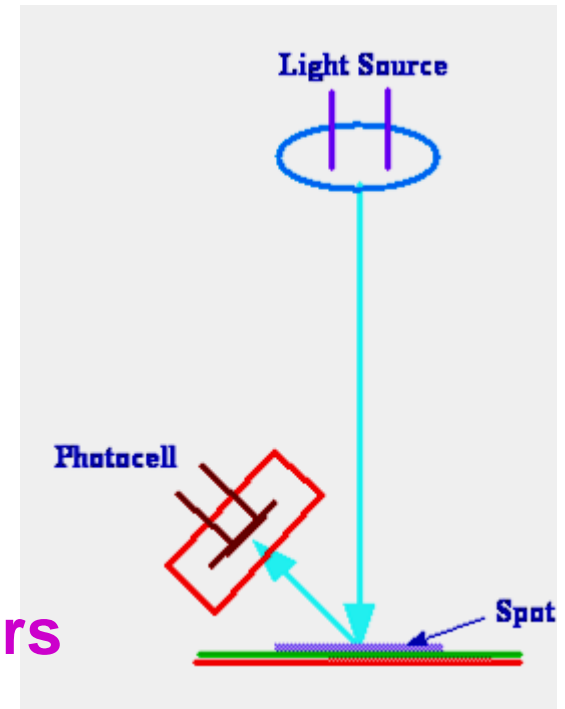

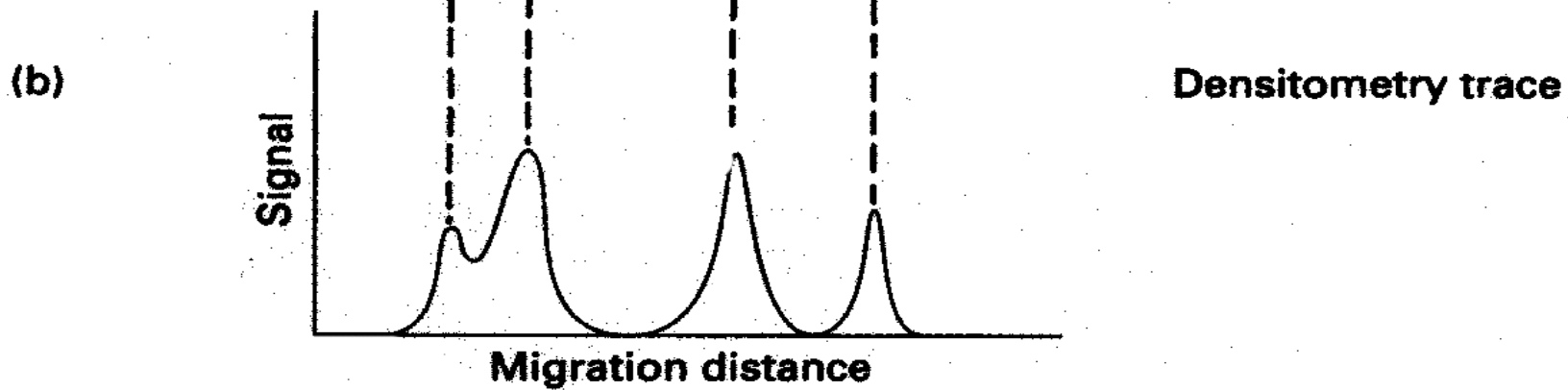
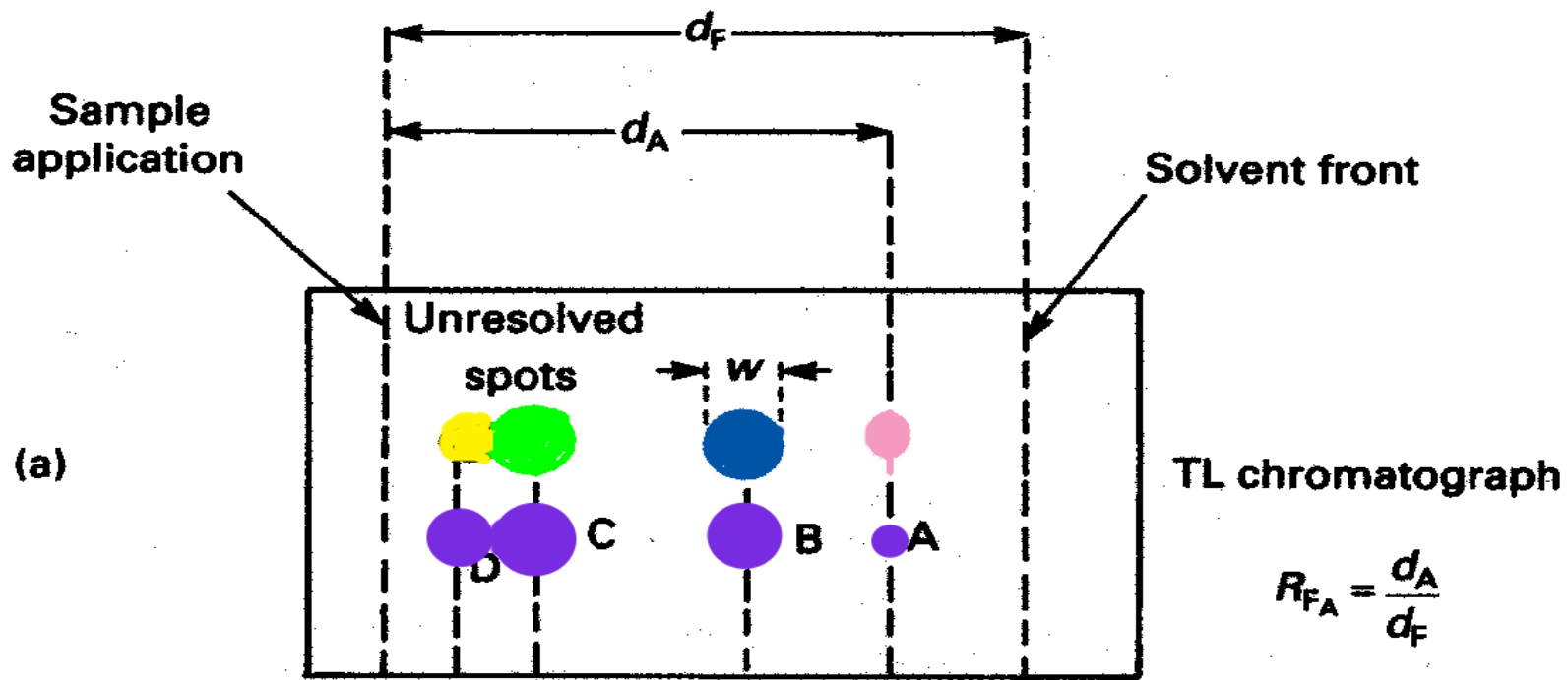

6- Identification of the spot components (unknowns):

1- Comparing the R_f (retention distance) of the known with the R_f of standards

R_f of component A =

$$\frac{\text{distance moved by component A } (d_A)}{\text{distance moved by a standard S } (d_S)}$$

R_f of component B =

$$\frac{d_B}{d_S}$$

The R_f value is a decimal fraction, generally only reported to two decimal places

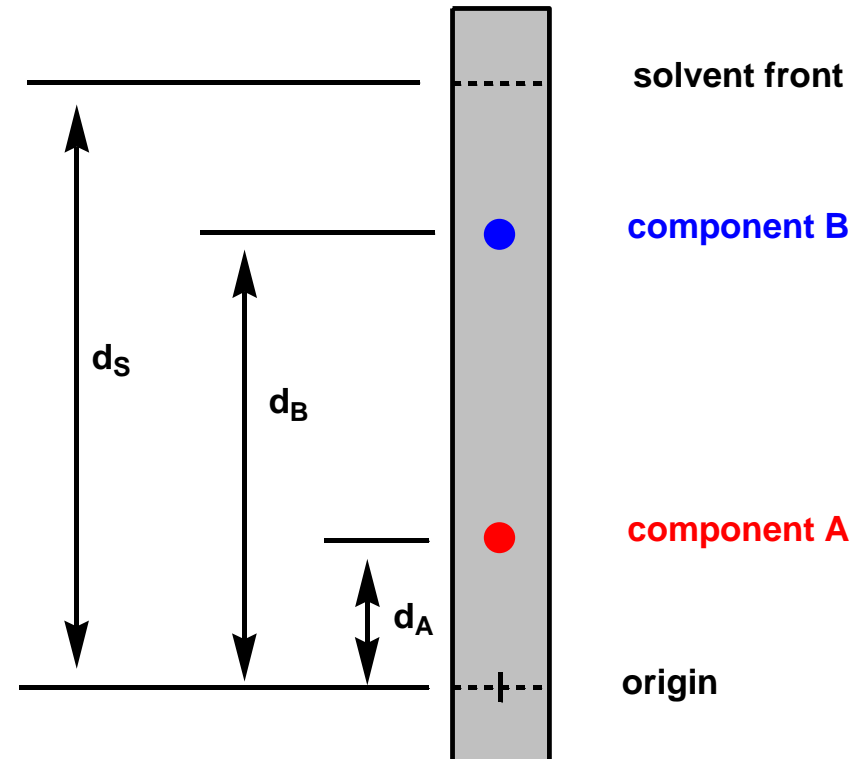

Calculation of R_f's

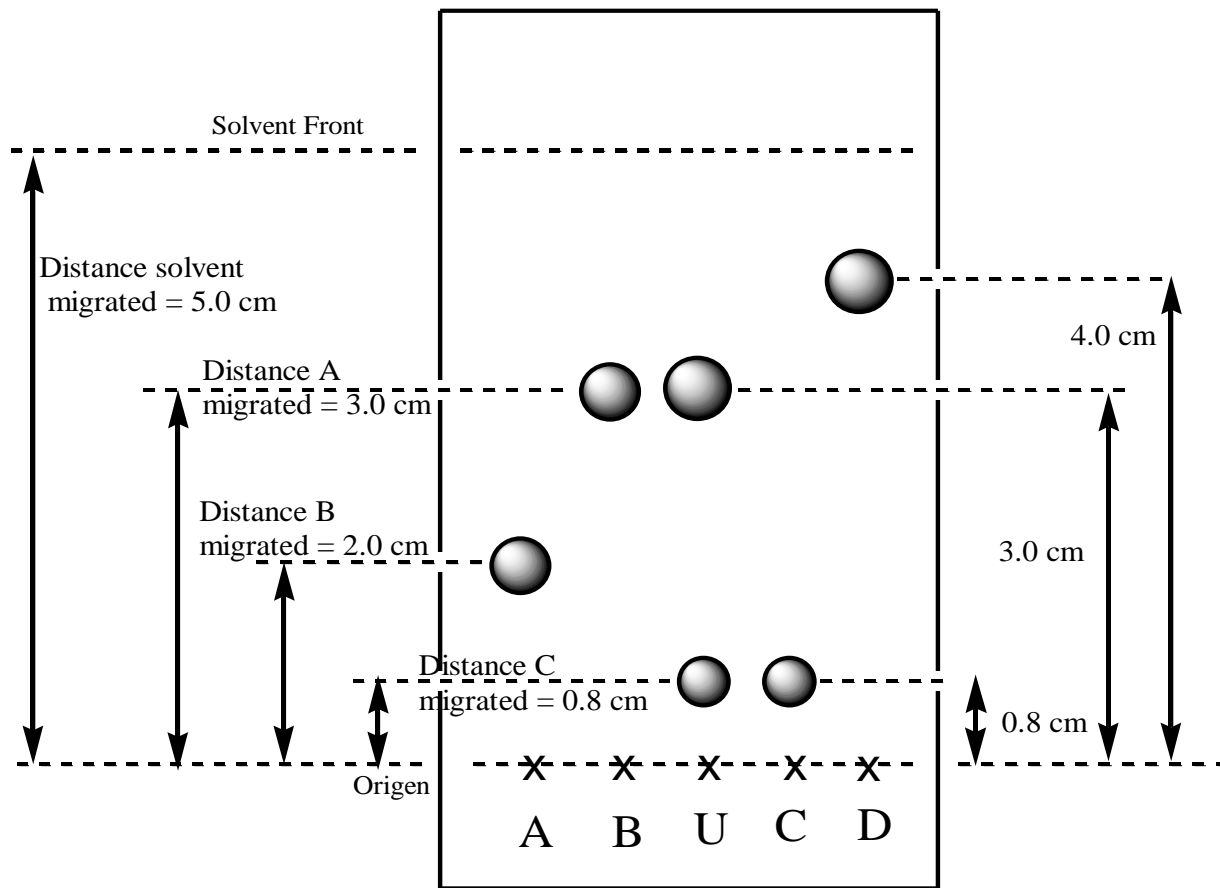

$$R_f (A) =$$

$$R_f (B) =$$

$$R_f (C) =$$

$$R_f (D) =$$

$$R_f (U_1) =$$

$$R_f (U_2) = \frac{0.8 \text{ cm}}{5.0 \text{ cm}} = 0.16$$

The R_f is defined as the distance the center of the spot moved divided by the distance the solvent front moved (both measured from the origin)

2- Comparison method:

In this method a component that is expected to be in the mixture is eluted at the same time and under the same conditions of the mixture. The two spots that have the same R_f –values are for the same compound.

3- Complete elution and identification method:

In this method the spots are completely removed (Scrape the solid support from the region containing the spot) and the residue is extracted using in an appropriate Solvent. The compound is identified by spectral methods (MS/ IR/ NMR)

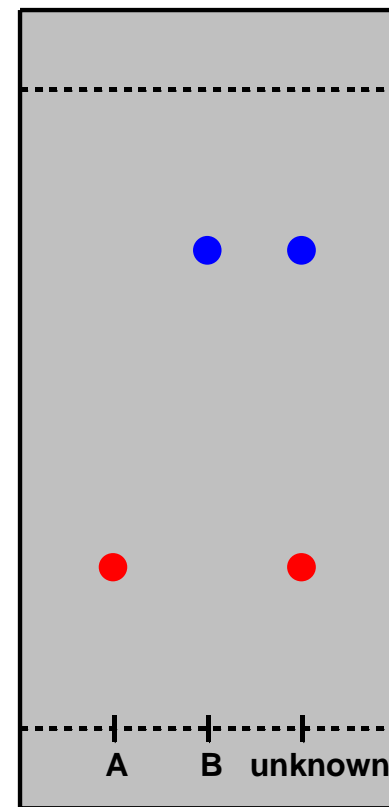

Comparison method

TLC Applications

- **Check of purity of samples**
- **Examination of reaction Progress and products**
- **Identification of compounds in mixtures**
- **Analysis of biochemical samples**
- **In pharmaceutical industry**
- **Separation of multi-component pharmaceutical formulations**
- **In food and cosmetic industry**
- **In medical diagnoses (diabetes and pregnancy tests)**
- **Analysis of biological samples and for studying drug metabolism**

Example-1: Monitoring of organic reactions:

Consider the reaction between phenol and nitric acid:

- Product is a mixture of: 2-nitrophenol and 4-nitrophenol, they can be separated using TLC.

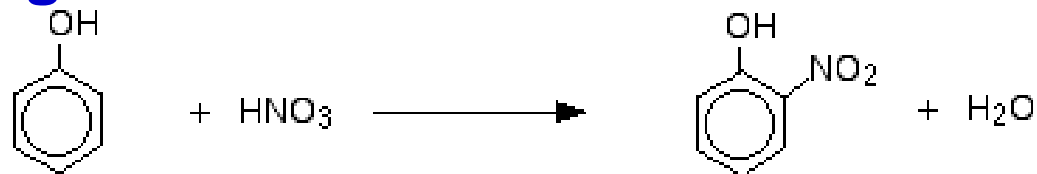
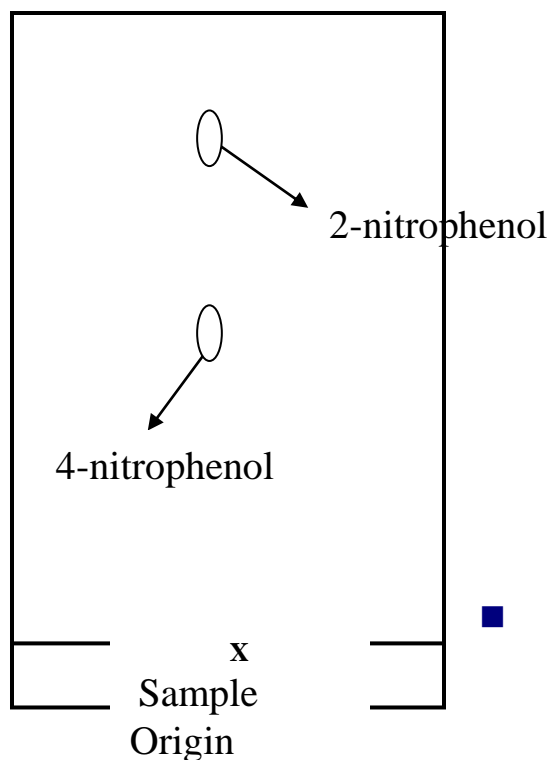

2-nitrophenol

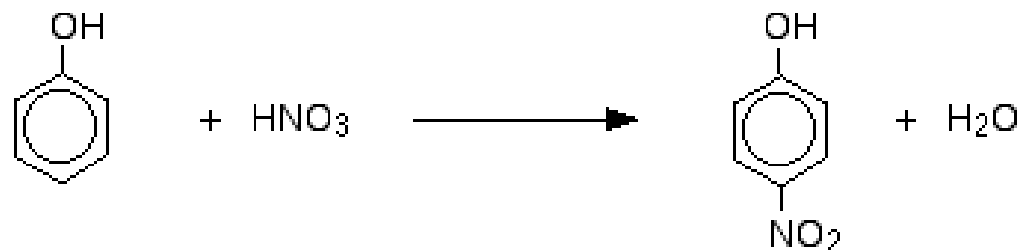

4-nitrophenol

- Intramolecular interactions are important, 2-nitrophenol can form an intramolecular H-bond while 4-nitrophenol can't.
- This intramolecular H-bond formation reduces the extent of intermolecular H-bonds between the gel and the 2-nitrophenol.

Example-2: Separation of drugs in samples

Predict the order of elution for these compounds.

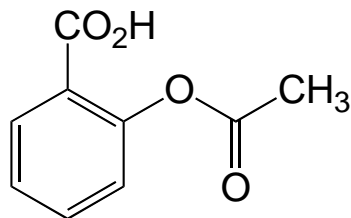
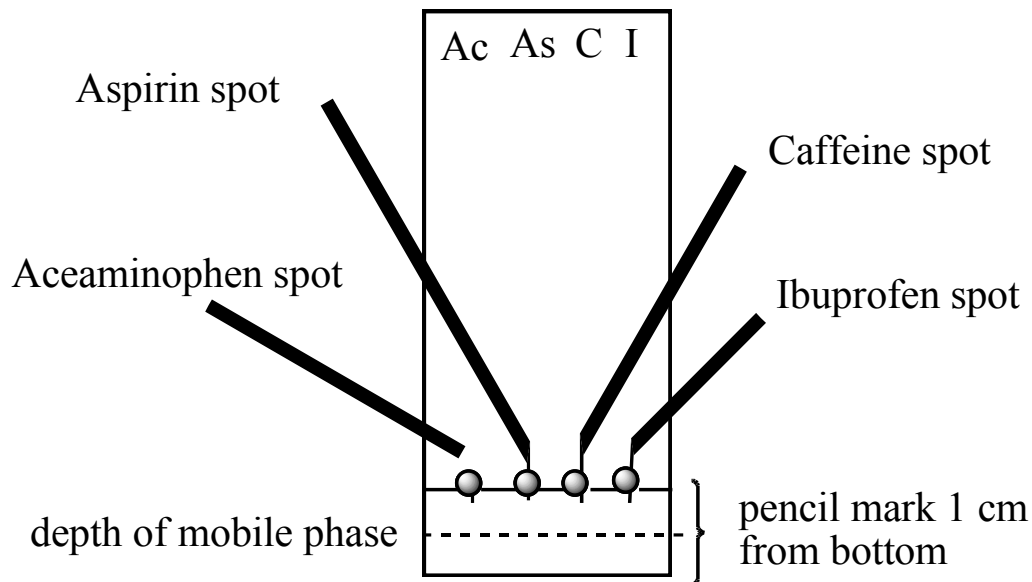

Aspirin

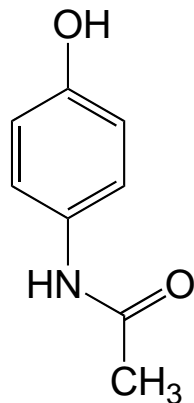

Acetaminophen

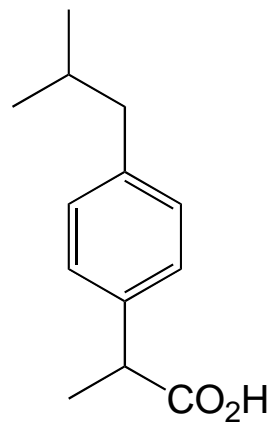

Ibuprofen

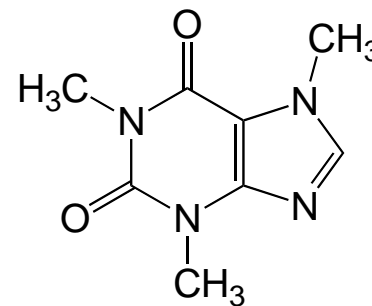

Caffeine

Example-3: Identifying compounds present in a given substance

- Spot the plate with **pure fluorene, fluorenone and fluorenol.**
- Spot the plate with an unknown mixture containing the above compound(s).
- Develop the plate in a screw cap glass bottle using CH_2Cl_2
- Visualize the spots using iodine vapor

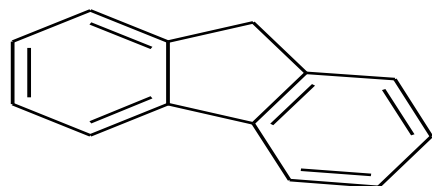

Fluorene

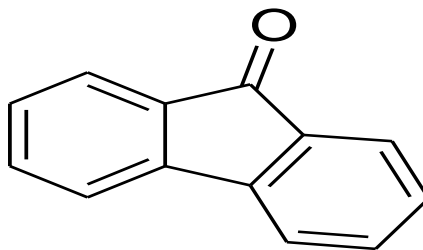

Fluorenone

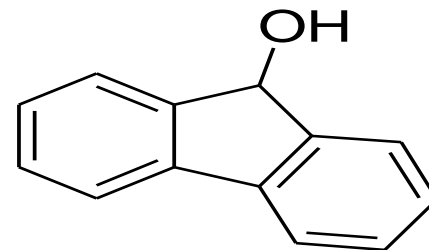

Fluorenol

What would be the relative order of separation on the TLC plate remembering that CH_2Cl_2 is not very polar?

Example-4: Quantitative Analysis:

In this case an accurate volume of samples are applied using syringes. The plates are developed as usual in the chromatographic tanks. After development the concentration of material can be determined by:

- **Spot area measurement: which is directly proportional to the conc. of materials.**
- **Photodensitometry: Measure transmittance, reflection or fluorescence of spots.**
- **Radioactivity: For radioactive materials.**

These measurements are done using TLC scanner connected to computer that perform all calculations.

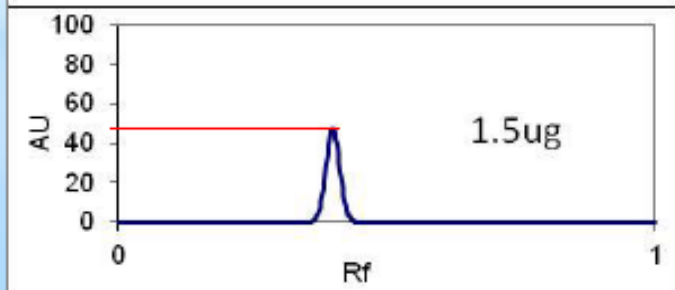
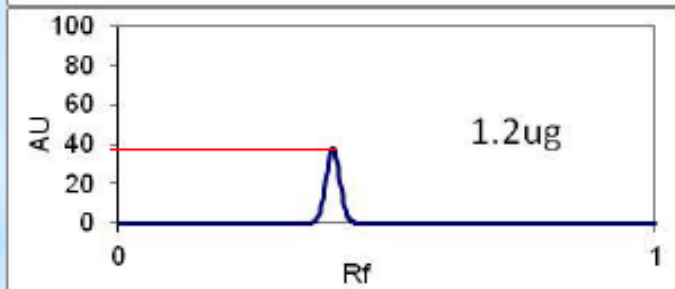
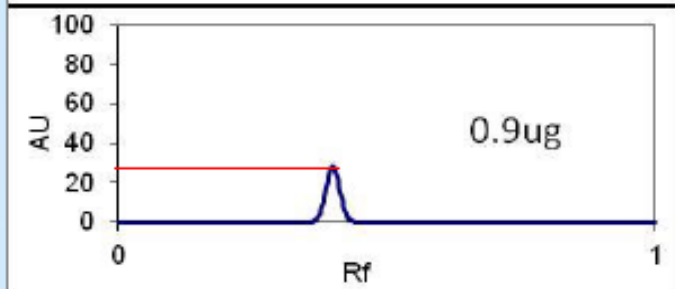
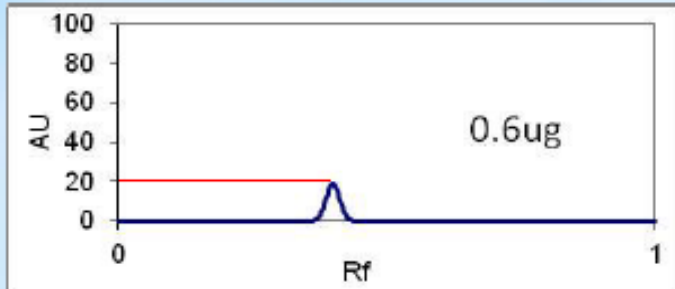

concentration ug/L	0,6	0,9	1,2	1,5
AU	20	30	40	50

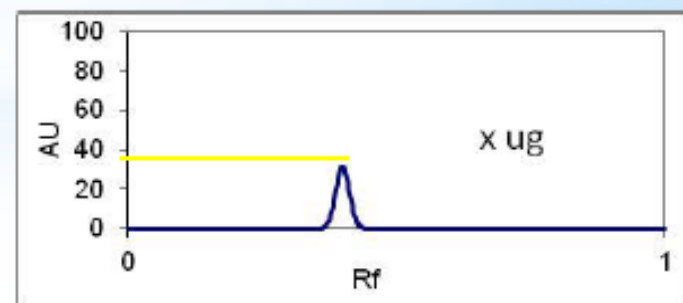
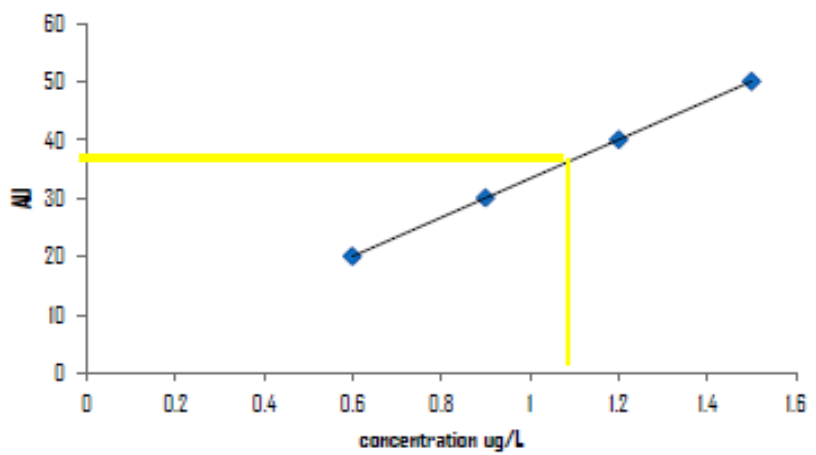

Example-5: Preparative TLC:

In preparative application, the mixture is applied as bands and a pilot or guide spots may be used in one side of the plate to enable the detection of the spots location.

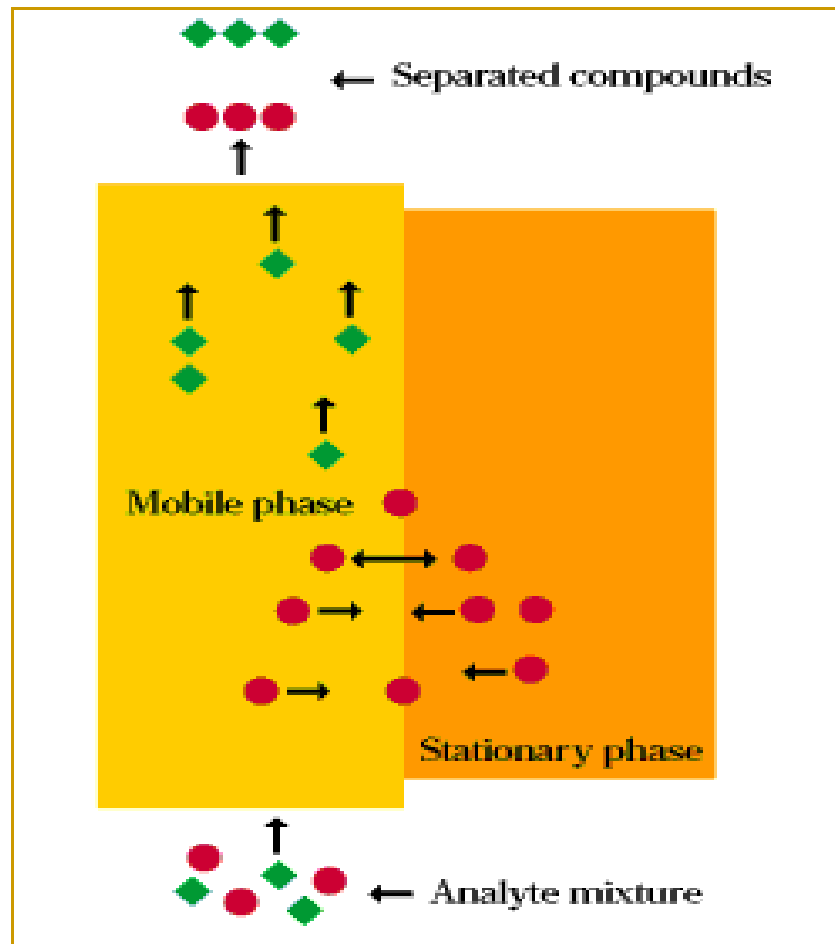

Advantages of TLC

- **Low cost**
- **Short analysis time**
- **Ease of sample preparation**
- **All spots can be visualized**
- **Sample cleanup is seldom necessary**
- **Adaptable to most pharmaceuticals**
- **Uses small quantities of solvents**
- **Requires minimal training**
- **Reliable and quick**
- **Minimal amount of equipment is needed**
- **Densitometers can be used to increase accuracy of spot concentration**

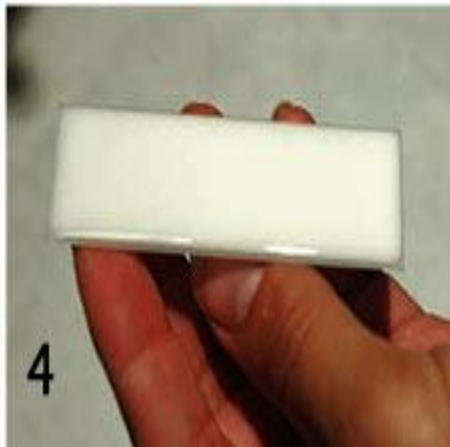
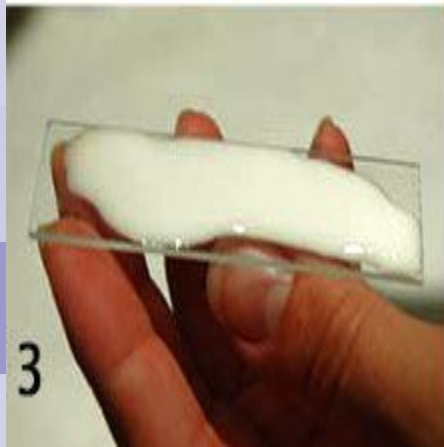
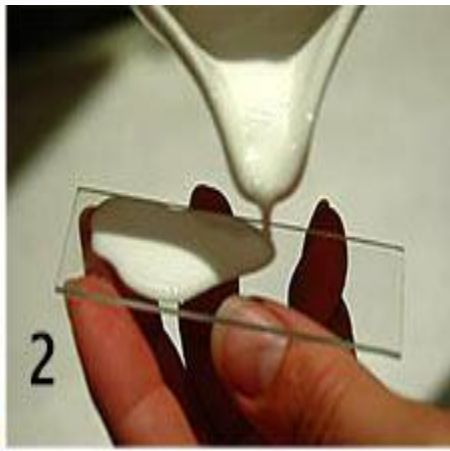
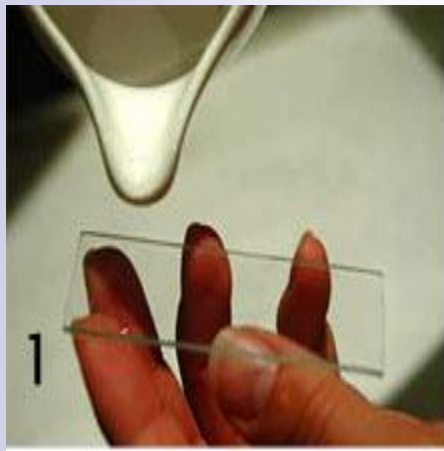

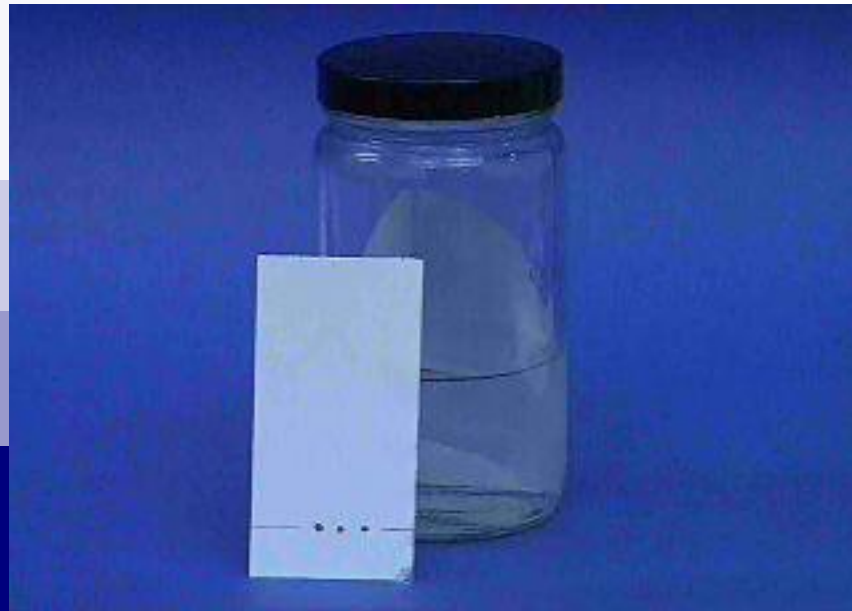

Coater, hand operated

